

TECHNICAL FEATURES	
External structure	Aluminium casing and vitroceramic glass
Dimensions	340 x 340 mm
Power	650W
Cooking surface	Vitroceramic glass.
Control panel	Capacitive touches 3 touches 4 digits Stainless steel frame. Remote drop-in control panel.
Amp	3A
Functions	On/Off, manual temperature setting (+/-) from 40° to 90°C by 5°C steps.
Power supply	230 V ; 208/240 V ; AC 50 - 60 Hz
Weight	8 kg kg / 17,3 lbs.
Standards	Complies with European standards for safety of electrical appliances.
Details & Options	Including a power cord without plug and a washable filter (wash regularly). Including stainless steel frame to drop in client structure for flushed installation. Including 2M cable between control panel and generator

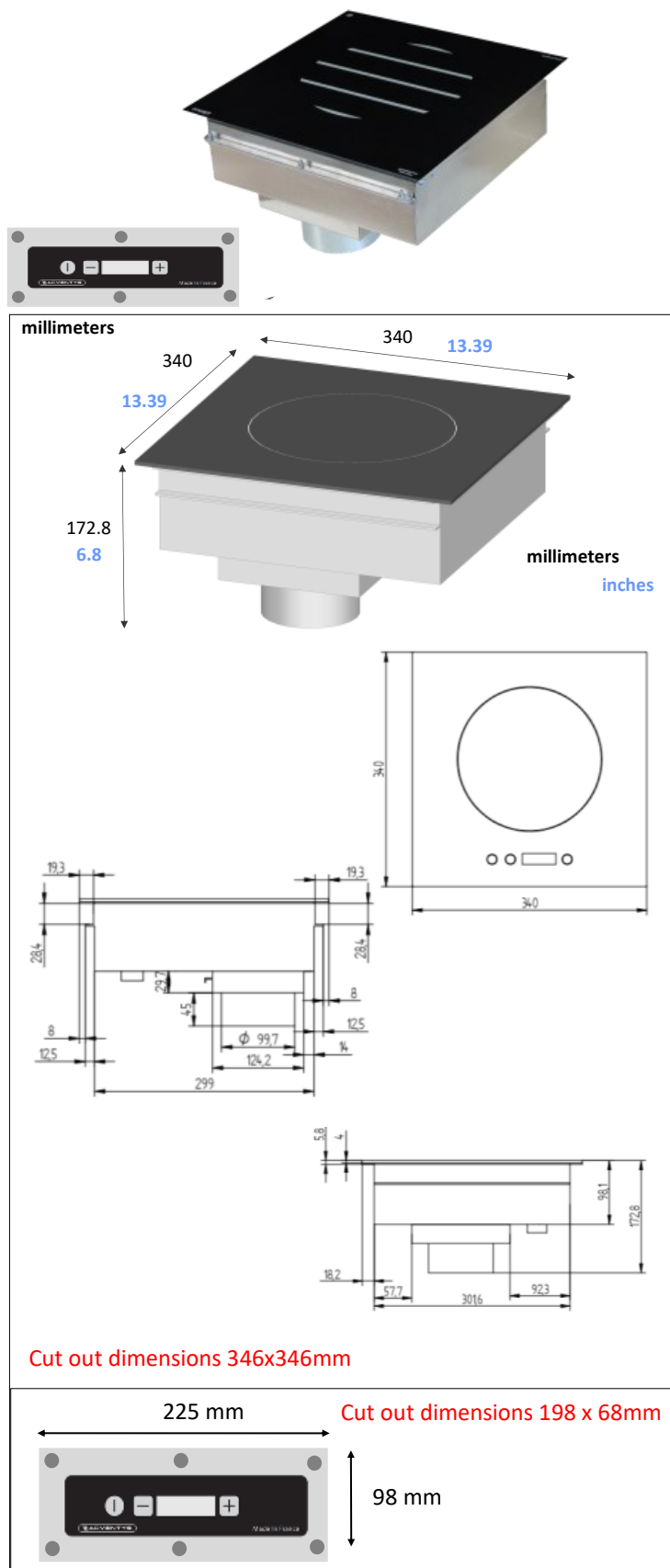

ADVENTYS
Route de Pagny - 21250 Seurre - France
www.adventys.com
sales@adventys.com
T: +33 3 80 20 46 15

Important note

Adventys reserves the right to modify specifications without notice.